

DATA SHEET



Flow sensor element

Description



Technical data

FLW-122	
Measuring range flow	0...100 m/s
Measuring principle	thermal
Response sensitivity	0,01 m/s
Accuracy	<3%
Reaction time T63	approx. 2 s
Operating temperature	-20...+150 °C
Temperature sensitivity	<0,1%/K depending on electronics and calibration
Electrical connection	3-polig
Nominal resistance heater	RH(0°C) = 45 Ω 5%
Nominal resistance sensor	RS(0°C) = 1200 Ω ±5%
Max. supply voltage	typ. 2-5 V bei Δ T=30 K (0 <Vström<100 m/s)
Max. heater voltage	3 V
Substrate material	Special ceramic-poor conductor of heat
Dimensions (without pins)	(LxBxH) 6,9x,2,4x0,6 mm
Art.- no.	FLW-122

Characteristic features

- Thermal optimized and efficient sensor structure
- Flow measurement in gases of 0...0,1 m/s to 0...100 m/s
- Fast reaction time
- Easy to electronically analyze and calibrate
- No mechanically moved parts
- Good reproducibility and long-term stability
- Ideal price-performance ratio
- Easy to install in custom-build housing

Typical areas of application

- Gaseous measuring media
- Building automation
- Automotive engineering
- Medical engineering
- Device monitoring
- Cooling devices
- Food industry

Features

The FLW-122 is a thermal sensor for measuring flow in gases.

It contains two platinum resistance elements in one chip. While the small, low-ohm element serves as heater, the high-ohm element is used to measure the reference temperature. Through the evaluation unit both Pt-elements are switched in a full bridge, so that through the applied voltage an adjustment on a firstly defined temperature difference between both Pt-elements takes place.

Since the heatloss of the heating element is dependent on the stream speed, the voltage which is fitting to the bridge poses a direct gauge for the stream speed.

Due to the little sensor mass there are fast response times and short heating periods. The device does not have any movable mechanical parts, so it is long-living and precise in a measuring range of 0 to 100 m/s. It is ideally suited for the building automation, automotive engineering and medical engineering because of its high reproducibility and long-term stability.

DATA SHEET



Flow sensor element

Dimensions

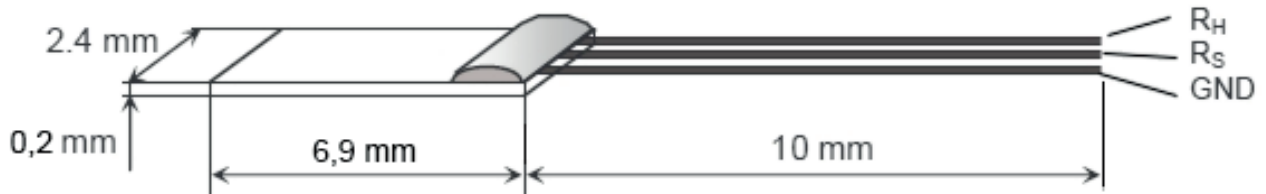

Connection (Example)

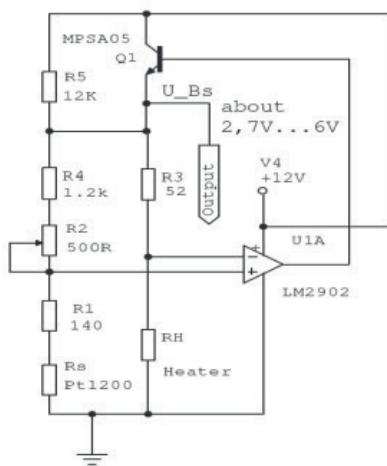

Both elements (Heater RH and sensor RS) can be switched in a bridge. The resistors R1,R2 and R3 are to dimensionate rightly to balance the bridge between RS and RH at a selectable temperature difference (ΔT). This is the condition to which the voltage fitting to the bridge is controlled.

When the stream speed changes, the heat loss of the heater changes too which affects the needed performance to hold up the temperature difference between RH and RS. The needed voltage at the bridge input therefore is a gauge for the stream speed.

The values for R1 .. R3 are dependent on the temperature difference (ΔT) and the medium that has to be measured. They are provided for the customer. For air and other gases you can see them in the connection-example on the left side. R2 should be able to be compensated $\pm 10\%$ for calibration purposes. The compensation procedure depends on the application. Both switching and curve representation are examples. Für the concrete application case a individual calibration is always needed.